

Encoders without bearings - absolute

Absolute encoder, 1 or 2 sensing head

Magnetic sensing, hollow shaft $\varnothing 30$ mm

Singleturn 13...16 bit, additional incremental signals 1024...8192

MHAD 50 - HDmag



MHAD 50 with cable

Features

- Absolute encoder with magnetic sensing and without bearings
- Absolute resolution max. 16 bit singleturn
- Additional incremental signals
- Robust and wearless
- Protection IP 67
- Large tolerances: axial ± 1 mm, radial max. 1 mm
- Very compact dimensions
- Simple mounting, easy adaptation
- LED functional display

Technical data - electrical ratings (SSI)

Voltage supply	4.5...30 VDC
Consumption w/o load	≤ 50 mA (24 VDC)
Interface	SSI
Function	Singleturn
Steps per turn	≤ 65536 / 16 bit
Sensing method	Magnetic
Absolute accuracy	$\pm 0.3^\circ$ (-40...+85 °C) $\pm 0.25^\circ$ (+20 °C)
Repeatability	0.3°
Code	Gray or binary
Code seque./sense of rot.	Positiv at CW
Inputs	SSI clock Zero setting input Counting direction
Additional output signals	Square-wave univ. HTL/RS422
Output stages	SSI data: Linedriver RS422
Interference immunity	DIN EN 61000-6-2
Emitted interference	DIN EN 61000-6-4

Technical data - electrical ratings (CANopen)

Voltage supply	4.5...30 VDC
Consumption w/o load	≤ 50 mA (24 VDC)
Interface	CANopen®
Function	Singleturn
Steps per turn	≤ 65536 / 16 bit
Sensing method	Magnetic
Absolute accuracy	$\pm 0.3^\circ$ (-40...+85 °C) $\pm 0.25^\circ$ (+20 °C)
Repeatability	0.3°
Code seque./sense of rot.	Positiv at CW
Additional output signals	Square-wave univ. HTL/RS422
Output stages	CAN-Bus, LV (3.3 V) compatible ISO11898
Device profile	CANopen / CIA DS-301 V4.02 (Komm.) DS-406 V3.0 (encoder profile) DSP 305 V1.0 (LSS)
Interference immunity	DIN EN 61000-6-2
Emitted interference	DIN EN 61000-6-4

Encoders without bearings - absolute

Absolute encoder, 1 or 2 sensing head

Magnetic sensing, hollow shaft $\varnothing 30$ mm

Singleturn 13...16 bit, additional incremental signals 1024...8192

MHAD 50 - HDmag

Terminal assignment

CANopen without incremental with connector M12, 5-pin or cable

Connec.	Core color	Signals	Description
Pin 1	–	n.c.	–
Pin 2	brown	+Vs	Voltage supply
Pin 3	white	CAN_GND/0 V	CAN Ground/volt. sup.
Pin 4	green	CAN_H	Bus (dominant HIGH)
Pin 5	yellow	CAN_L	Bus (dominant LOW)
	grey	CAN_GND	CAN Ground
	pink	n.c.	–
	blue	n.c.	–
	red	n.c.	–



Screen: connected to housing
Cable: PUR 4 x 2 x 0.14 mm², 1 m / $\varnothing 6$ mm
Bending rad.: R ≥ 49 mm

CANopen with incremental with connector M12, 8-pin or cable

Connec.	Core color	Signals	Description
Pin 1	white	CAN_GND/0 V	CAN Ground/volt. sup.
Pin 2	brown	+Vs	Voltage supply
Pin 3	green	CAN_H	Bus (dominant HIGH)
Pin 4	yellow	CAN_L	Bus (dominant LOW)
Pin 5	grey	CHA	Incremental
Pin 6	pink	CHA inv.	Incremental
Pin 7	blue	CHB	Incremental
Pin 8	red	CHB inv.	Incremental



Screen: connected to housing
Cable: PUR 4 x 2 x 0.14 mm², 1 m / $\varnothing 6$ mm
Bending rad.: R ≥ 49 mm

Please use screened cables and cores twisted in pairs (Data+/Data-, CAN_H/CAN_L, CHA/CHA inv., CHB/CHB inv.) for connection cables.

SSI without incremental with connector M12, 8-pin or cable

Connec.	Core color	Signals	Description
Pin 1	white	0 V	Voltage supply
Pin 2	brown	+Vs	Voltage supply
Pin 3	green	Clock+	Clock signal
Pin 4	yellow	Clock-	Clock signal
Pin 5	grey	Data+	Data signal
Pin 6	pink	Data-	Data signal
Pin 7	blue	Zero	Zero setting
Pin 8	red	DIR	Rotating direction



Screen: connected to housing
Cable: PUR 4 x 2 x 0.14 mm², 1 m / $\varnothing 6$ mm
Bending rad.: R ≥ 49 mm

SSI with incremental with connector M12, 12-pin or cable

Connec.	Core color	Signals	Description
Pin 1	brown	+Vs	Voltage supply
Pin 2	blue	Zero	Zero setting
Pin 3	white	0 V	Voltage supply
Pin 4	green	Clock+	Clock signal
Pin 5	pink	Data-	Data signal
Pin 6	yellow	Clock-	Clock signal
Pin 7	black	CHA	Incremental
Pin 8	grey	Data+	Data signal
Pin 9	red	DIR	Rotating direction
Pin 10	violet	CHA inv.	Incremental
Pin 11	grey/pink	CHB	Incremental
Pin 12	red/blue	CHB inv.	Incremental



Screen: connected to housing
Cable: PUR 6 x 2 x 0.14 mm², 1 m / $\varnothing 7$ mm
Bending rad.: R ≥ 57 mm

Please use screened cables and cores twisted in pairs (Data+/Data-, Clock+/Clock-, CHA/CHA inv., CHB/CHB inv.) for connection cables.

Data transfer

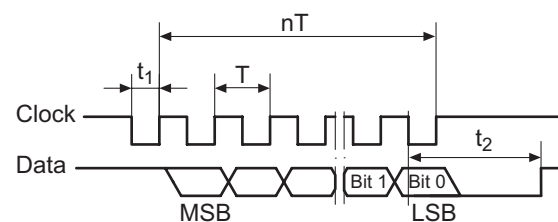

$$T = 0.5 \dots 10 \mu\text{s} \quad t_1 = 0.25 \dots 5 \mu\text{s}$$

$$t_2 \leq 12 \dots 25 \mu\text{s} \quad f \text{ max. } 2 \text{ MHz}$$

Encoders without bearings - absolute

Absolute encoder, 1 or 2 sensing head

Magnetic sensing, hollow shaft $\varnothing 30$ mm

Singleturn 13...16 bit, additional incremental signals 1024...8192

MHAD 50 - HDmag

Terminal significance	
+Vs	Encoder supply voltage.
0 V	Encoder ground connection relating to +Vs.
Data+	Positive SSI data output.
Data-	Negative SSI data output.
Clock+	Positive SSI clock input.
Clock-	Negative SSI clock input.
Zero	Input for setting a zero point anywhere within the encoder resolution. The zero setting operation is triggered by a High impulse after the rotation direction selection (DIR). Connect to 0 V after setting operation for maximum interference immunity. Pulse duration >100 ms Level HIGH >0.7 x (+Vs) Level LOW <0.3 x (+Vs) (4.5 V \leq (+Vs) \leq 30 V)
DIR	UP/DOWN counting direction input. This input is standard on High. DIR High means ascending position value with clockwise (cw) rotation direction. Connect to +Vs or 0 V for maximum interference according to rotation direction Level HIGH >0.7 x (+Vs) Level LOW <0.3 x (+Vs) (4.5 V \leq (+Vs) \leq 30 V)
DATAVALID	Diagnostic output upon request.

Output signals

Version with additional square wave signals HTL or RS422 at rotating direction cw

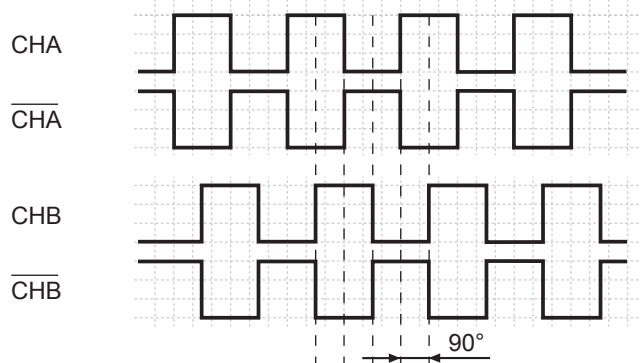

LED functional display

SSI	
LED	Description / possible causes
Green*	<ul style="list-style-type: none"> Voltage supply is present Encoder is OPERATIONAL
Red	<ul style="list-style-type: none"> Rotor not present, not correctly mounted or damaged Mounting tolerances not respected Internal error
Off	<ul style="list-style-type: none"> Sensor is not present Voltage supply not available or too low Internal error

CANopen	
LED	Description / possible causes
Green* **	<ul style="list-style-type: none"> Voltage supply is present Encoder is in the OPERATIONAL state
Red	<ul style="list-style-type: none"> Rotor not present, not correctly mounted or damaged Mounting tolerances not respected Internal error
Green single flash**	<ul style="list-style-type: none"> The device is in the STOPPED state
Green blinking**	<ul style="list-style-type: none"> The device is in the PREOPERATIONAL state
Off	<ul style="list-style-type: none"> Sensor is not present Voltage supply not available or too low Internal error

* While the whole rotation the LED must emit green light.
** CAN RUN LED according to CiA DR-303-3.

Trigger level

Outputs	RS422
Output level High	>2.4 V (I = -20 mA)
Output level Low	<0.5 V (I = 20 mA)
Load High / Low	<20 mA

Outputs	HTL
Output level High	>+Vs -3 V (I = -20 mA)
Output level Low	<0.5 V (I = 20 mA)
Load High / Low	<20 mA

Encoders without bearings - absolute

Absolute encoder, 1 or 2 sensing head

Magnetic sensing, hollow shaft $\varnothing 30$ mm

Singleturn 13...16 bit, additional incremental signals 1024...8192

MHAD 50 - HDmag

Dimensions

MHAD with cable

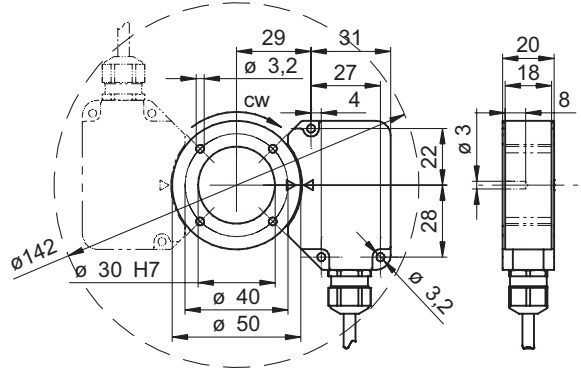

MHAD with connector M12

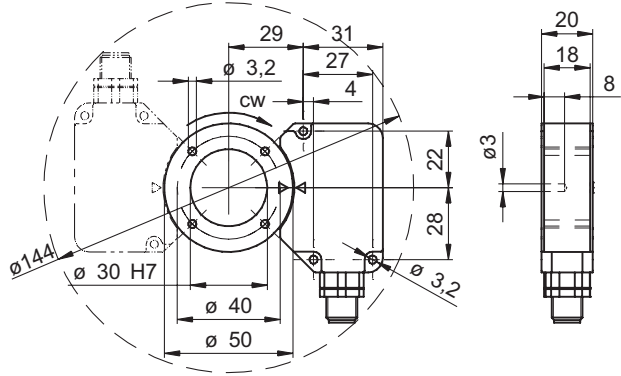

MHAD mounting tolerance

